



**AQUIND Limited**

---

## **AQUIND INTERCONNECTOR**

### **Compulsory Aquisition Hearing 1 – Appendix 1 - Exhibit 4 Transformer Transport Arrangement**

The Planning Act 2008

Infrastructure Planning (Examination Procedure) Rules 2010, Rule 8(c)

Document Ref: 7.9.18.4

PINS Ref.: EN020022

SIDE ELEVATION VIEW. SCALE 1:225

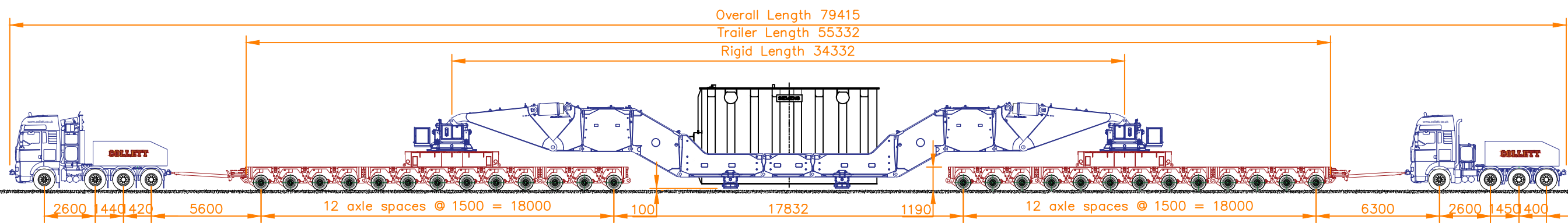

TRAF0 ON BEAMS REAR ELEVATION VIEW. SCALE 1:75

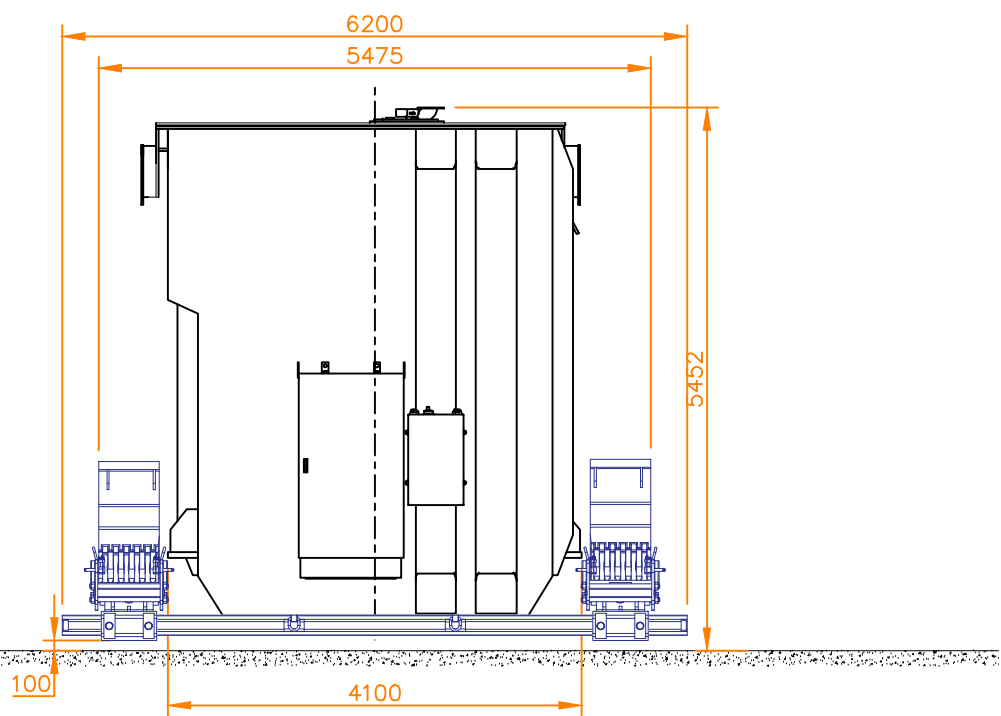

TURNING PLAN VIEW. SCALE 1:400

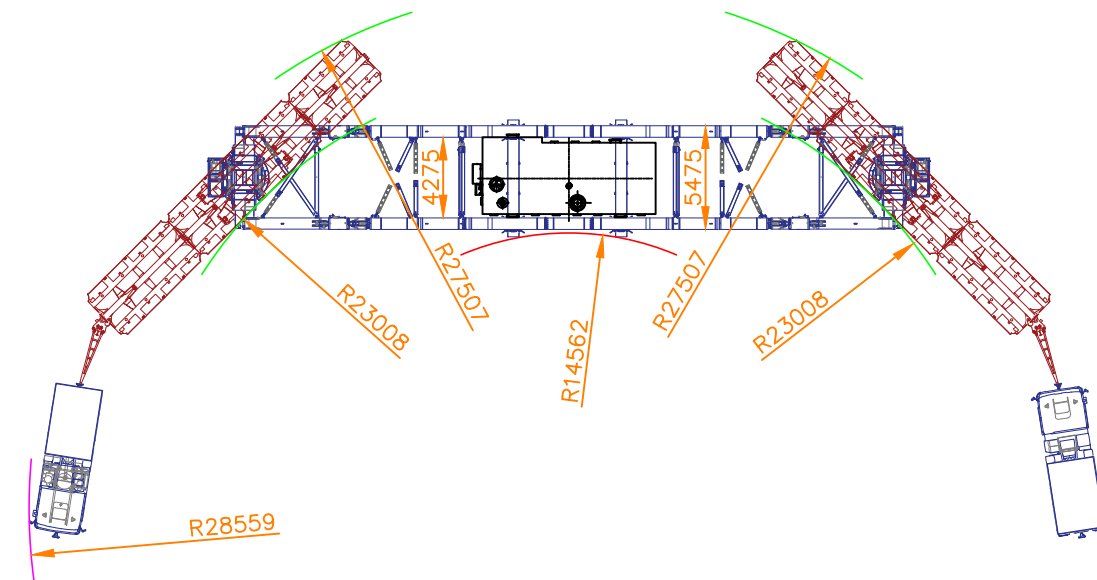

END ELEVATION VIEW OF MODULAR AXLES. SCALE 1:50

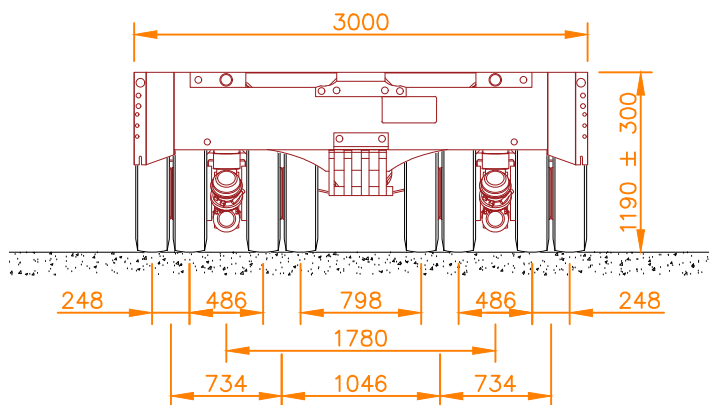

Weights Table		
Type	Description	Weight
Type of Trailer	13 Axle Girder Set 13 Axle	160.820 t
Type of Load	Transformer	332.000 t
	Total loaded weight excluding tractor units	492.820 t
	Load per axle line on trailer	15.275 t
	Load per axle per file	7.638 t
	Load per wheel on trailer	1.909 t
Abnormal Load Classification: <b>Special Order (BE16)</b>		

**For Information**

- THIS DRAWING IS PRELIMINARY AND IS RELEASED FOR INFORMATION ONLY.
- ALL DIMENSIONS ARE IN MILLIMETRES (mm) UNLESS OTHERWISE STATED.
- ALL WEIGHTS ARE IN METRIC TONNES (t) UNLESS OTHERWISE STATED.
- THE CLIENT IS RESPONSIBLE FOR THE STRUCTURAL INTEGRITY OF THE LOAD TRANSPORTED.
- THE CLIENT IS TO IDENTIFY AND CONFIRM THE SUITABILITY OF THE SUPPORT POINTS ON THE LOAD TO BE UTILISED DURING TRANSPORT.
- ALL EQUIPMENT IS SUPPLIED IN ACCORDANCE WITH COLLETT & SONS LIMITED TERMS AND CONDITIONS, AND THE RELEVANT R.H.A. 2009 TERMS AND CONDITIONS.
- WITHOUT AUTHORISED SIGNATURES THIS DOCUMENT IS UNCONTROLLED, NOT BINDING AND FOR INDICATIVE PURPOSES ONLY.

Drawn by:	Date:	Checked by:	Date:
Rev: <b>00</b>	<b>A.Abdallah</b>	<b>27/08/2019</b>	<b>E.Crosby</b>
Description: First issue.			
Client:		<b>WSP</b>	
Project:		<b>AQUIND</b>	
Title: <b>Transformer Transport Arrangement</b>			
<b>COLLETT</b> EXPERTS IN MOTION		COLLETT & SONS LTD Mistral Point A.W Nielsen Road Goole East Yorkshire DN14 6UE Tel: 08456 255233 Fax: 08456 255277 Web: <a href="http://www.collett.co.uk">www.collett.co.uk</a>	
THIS DRAWING AND ALL THE INFORMATION IT CONTAINS ARE THE PROPERTY OF COLLETT & SONS LTD AND SHALL BE TREATED AS CONFIDENTIAL UNLESS CONTRACTUALLY SPECIFIED OTHERWISE. IT MUST NOT BE COPIED, RE-PRODUCED OR DIVULGED TO A THIRD PARTY WITHOUT THE EXPRESSED PERMISSION FROM COLLETT & SONS LTD.			
Paper Size:	Scale:	Project No:	Drawing No:
<b>A3</b>	<b>As Noted</b>	<b>333100</b>	<b>COL-D-333100-1-1</b>
			Sheet No: <b>1 of 1</b>

